



Welcome to
Calgary Renewable Energy Meetings
March 21, 2026

BALCONY SOLAR SYSTEMS
Benefits and Risks

Presented by Ken Hogg M.Eng., P.Eng.
Founder of Alberta Renewable Energy Alliance

OVERVIEW

- What is Balcony Solar
- Germany's expansion of Balcony Solar
- Risks of DIY solar systems
- Utah's experiment in Balcony Solar
- Alternatives to Grid tied solar systems
- Cost and Benefits of small DIY solar
- Alberta's electricity grid carbon emission intensity

What is Balcony Solar?



Definition

Compact, modular photovoltaic units designed for limited spaces like balconies or patios.

Key components

PV modules/panels, microinverter (DC→AC), wiring, and non-roof mounting hardware.

Typical output

About 600 -800 watts per unit for small-scale residential generation.

Typical German Balcony Solar Diagram

- **Solar Panels (PV Modules):** Usually 1-2 panels, producing DC power.
- **Microinverter:** Converts DC to AC (max 800W, previously 600W).
- **AC Cable/Socket:** Plugs directly into a wall outlet (Schuko plug).

660W Balcony On-Grid Solar System

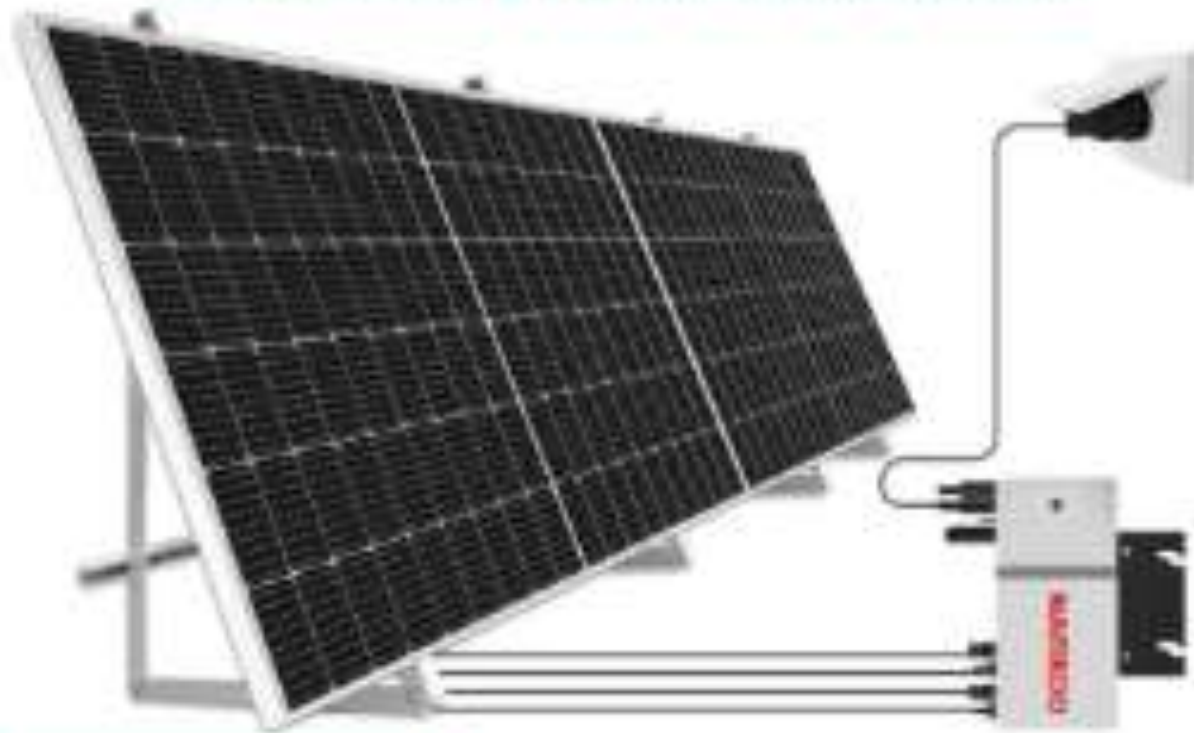



Germany



Balcony PB kit spot price in Germany (€/Wp, documented ranges 2019-2025)

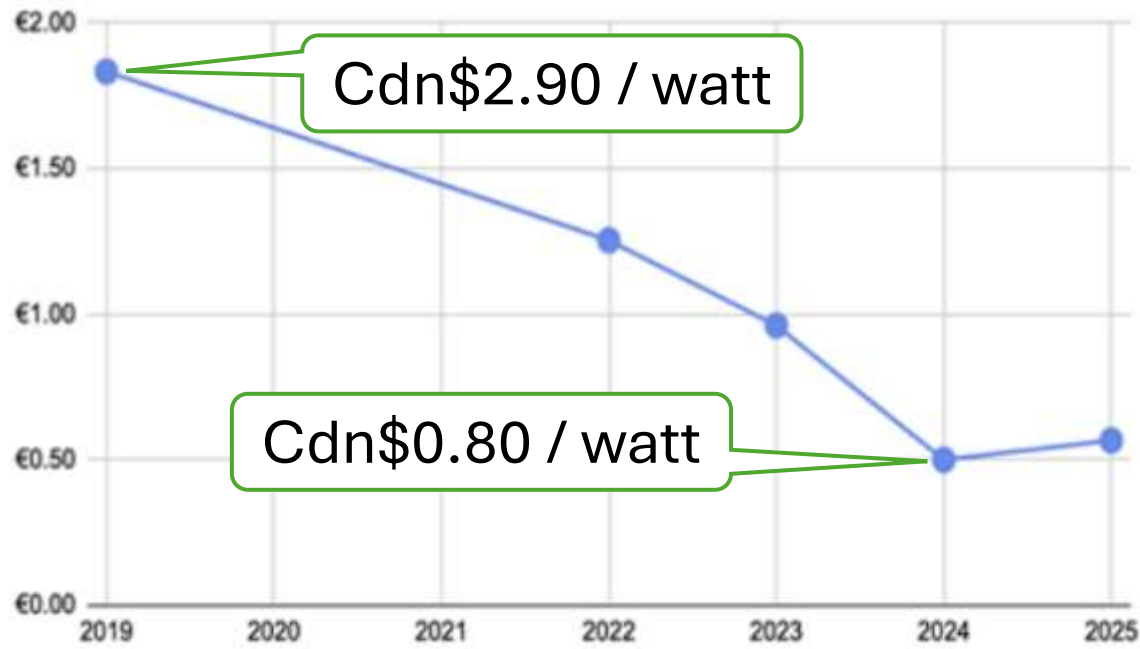

Source: Priwatt, HTW Berlin, Business Insider, Heise Online, ADAC, Finanztip

Registered Balcony Solar Units in Germany, 2019-Q2 2025

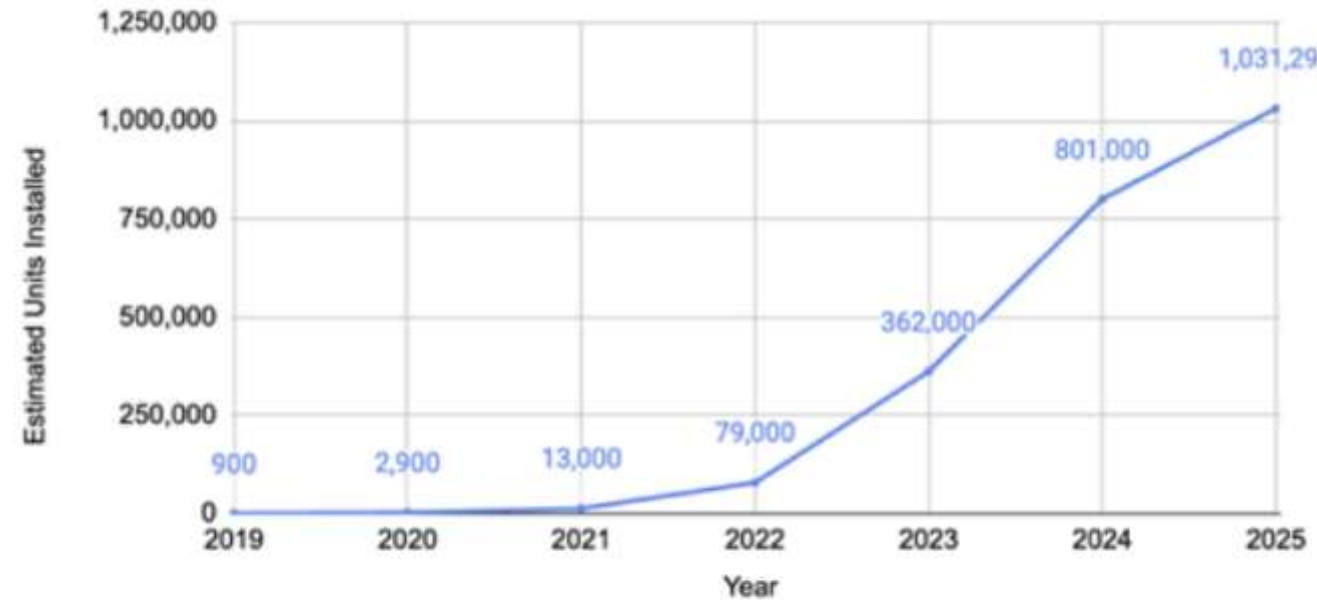

Source: Umweltbundesamt (UBA) 2025, Bundesnetzagentur MaStR 2025, BSW-Solar (2025)



© Hendrik Schmidt/dpa/picture alliance

Falling prices, improved technology and political support have helped drive a German balcony-solar boom

Image: Hendrik Schmidt/dpa/picture alliance

Key advantages of balcony solar in Germany

- Ease of Installation and portability
- Specifically designed to fasten on balconies to save space
- Approved to be plugged into a standard wall outlet
- Can reduce electricity costs by up to 30%
- Accessibility to apartment renters or condo owners
- Low cost (\$300 to \$1,200) allows payback in 3 to 4 years
- Reduces carbon emissions and reliance on fossil fuels

Risks

1. Backfeeding and Fire Risk (The "Breaker Masking" Concern)

- **What is it?** Balcony solar devices send power into a household socket, feeding it into a circuit. If you have other appliances drawing power on that same circuit, the total power draw at the outlet could theoretically exceed the capacity of the wiring, even if the circuit breaker doesn't trip. This is because the circuit breaker only measures power leaving the breaker box, not the power being injected midway.
- **Why it rarely happens in Germany:** Germany has strict standards. The limit for plug-in solar devices was recently increased to **800 watts**. This amount is low enough that, even in older homes, the wiring can typically handle the heating that occurs in worst-case scenarios.
- **When a fire could happen:** Fire risks are associated with using cheap, non-certified components, using extension cords, or tampering with the device to add illegal batteries.

2. Mandatory Safety Features

- **Anti-Islanding Protection:** All legal balcony solar inverters must meet VDE standards (e.g., VDE-AR-N 4105). This requires the inverter to shut down within a fraction of a second if the grid loses power (e.g., a power outage or if the unit is unplugged). This prevents electric shock for utility workers and prevents feeding power into a dead circuit.
- **Dedicated Circuits Recommended:** While many use standard "Schuko" sockets, using a dedicated circuit for the unit eliminates overloading risks.

3. Regulations and Safe Usage in Germany

- **Limits:** The maximum inverter capacity is **800 watts**.
- **Registration:** Units must be registered with the *Bundesnetzagentur* (Federal Network Agency) to ensure grid compatibility.
- **Component Quality:** It is recommended to use products with a CE certification and VDE standards to ensure safety.
- **Installation:** Only one unit per outlet/circuit should be used to prevent additive overcurrent.

Balcony solar systems must be registered in Germany



What is the registration deadline?

A1: Registration must be completed within one month after the system is officially activated.



What are the penalties for failing to register on time?

A2: If you miss the registration deadline, your subsidies may be temporarily withheld or completely forfeited. Additionally, failing to register in MaStR is considered illegal in Germany.

Balcony solar systems must be registered in Germany



Does the device need to be registered if it is not connected to the grid?

A3: Yes, of course.



Can I delete the registered information myself?

A4: No, you can't delete it yourself. You can request removal, or update it to decommissioned if the device is no longer in use.



Where we are in the U.S.



Average rooftop solar system costs of **\$18K**.



An **\$18K** system in Utah, would save a home \approx **\$1,000/yr** with a payback period \approx **18 yrs**.



\approx **1/2** of system costs are **soft costs** – which plug-in solar eliminates.

Rooftop Solar Prices Have Stagnated

US Residential PV Installed System Cost Breakdown (\$/Wdc) 2010–2024

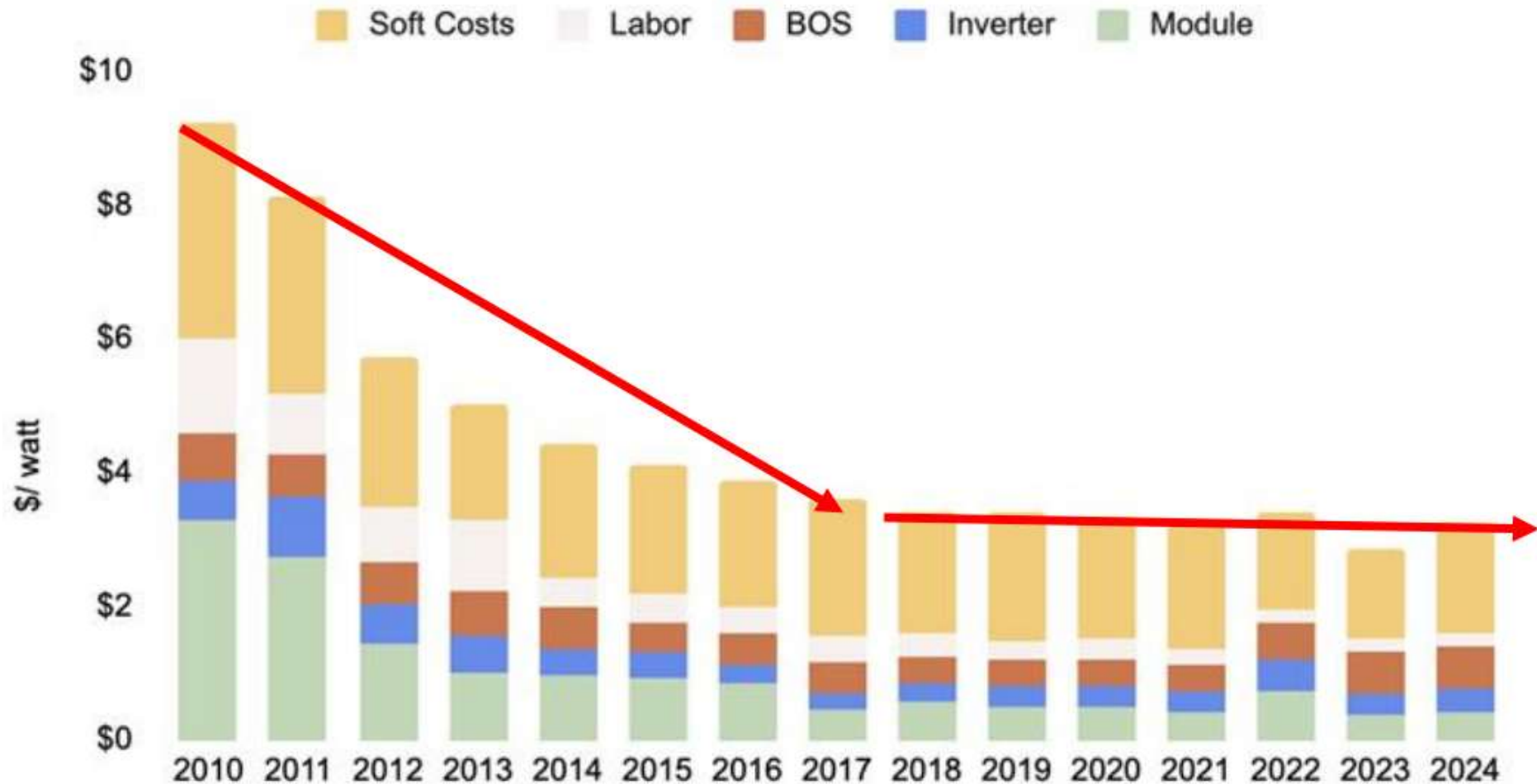

Source: NREL (2025)

Plug-in Solar = Energy Affordability



Renewable energy grows fastest when it saves people money.

Solar hardware has decreased significantly in the last 50 years, by roughly **99.7%**.

As the # of global installations double, the price continues to drop by **≈20%**.

Around **2021-23**, solar + battery overtook natural gas as the cheapest form of electricity.

Global solar prices are currently at **\$0.26/watt.**



Utah is leading the way with the solution.

H.B. 340 Solar Power Amendments

Bill Text

Enrolled [Printer Friendly](#)

Solar Power Amendments

2025 GENERAL SESSION

STATE OF UTAH

Chief Sponsor: Raymond P. Ward

Senate Sponsor: Wayne A. Harper

Hearings/Debate

H.B. 340

Bill Sponsor:



Rep. Ward,
Raymond P.

Floor Sponsor:



Sen. Harper, Wayne
A.

Drafting Attorney: Scott Elder

Fiscal Analyst: Noah Matthew Hansen

Given the political environment in the U.S. and divisiveness over climate change, it might come as a surprise that a red state like Utah is leading the charge. Ward says it was a matter of offering residents an opportunity to save money, and his legislation gets "the government out of their way."

He says it wasn't that plug-and-play solar units were prohibited, but rather that the regulations only covered rooftop solar panel systems, which weren't allowed to be plugged directly into an existing electrical system and had a contract with the local utility.

"That makes sense if you're going to cover your whole roof with them and expect the utility to pay you some money for that power," Ward said. "But it doesn't make sense if you're just buying something little and plugging it in and not asking [the utility] for anything."

Utilities got on board, he says, once they realized they wouldn't have to compensate customers for the power they were generating.

Key Details on Utah Balcony Solar:

- **Legal Status:** Authorized under HB 340, bypassing typical utility approval processes for small, plug-in systems.
- **Capacity Limit:** Residents can install up to 1.2 kW (1,200 watts) of solar panels.
- **Safety Requirements:** Systems must comply with safety standards (UL listed).
- **Ease of Installation:** Designed for apartments and condos, these systems typically involve mounting panels on a balcony railing and plugging them into an exterior outlet.
- **Cost and Savings:** Kits can cost between \$400 and \$2,000. A 800W system can cover 15%–25% of an apartment's electricity needs.
- **Mechanism:** The panels feed power directly into the home circuit, reducing the reliance on the grid and lowering electricity bills.

This legislation was designed to make solar accessible to apartment dwellers and homeowners who cannot install traditional rooftop solar.

Pembina Release on Renewables Moratorium

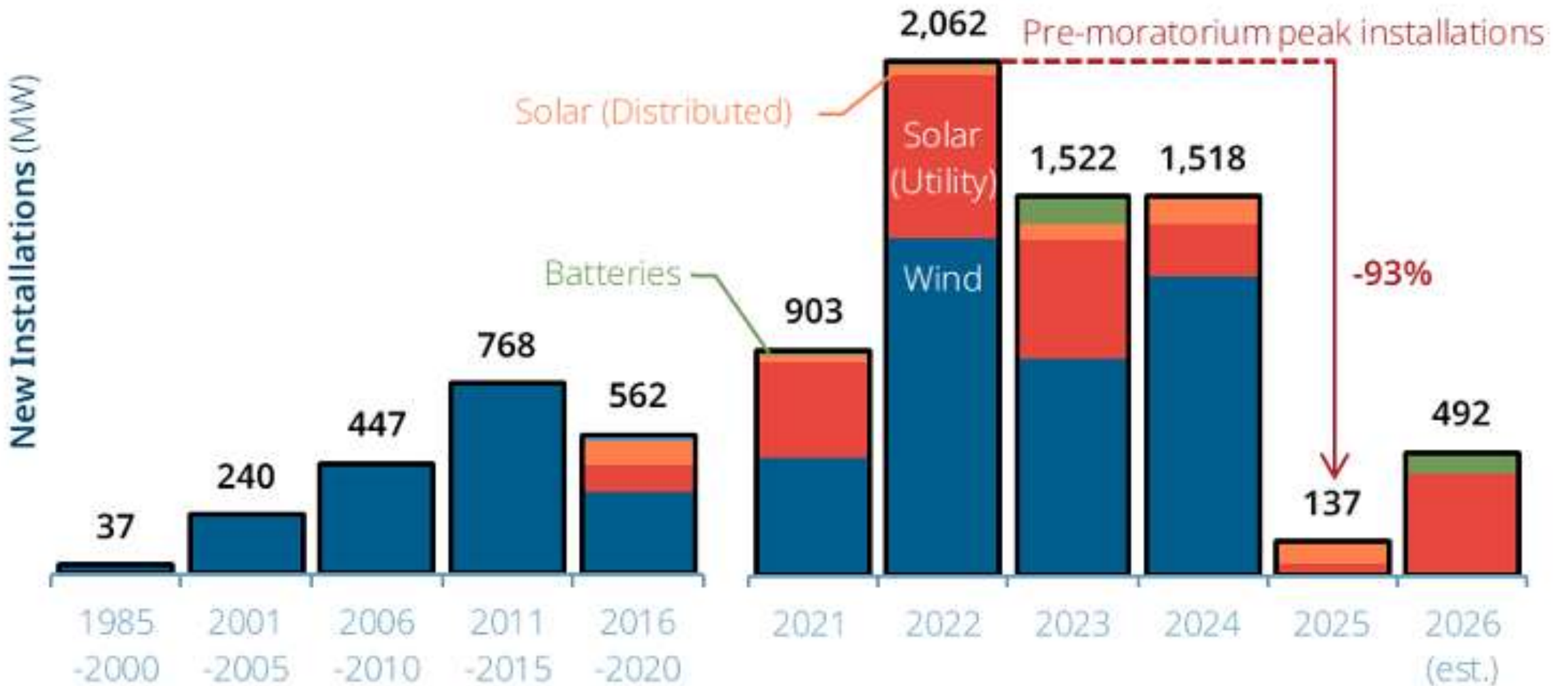

Alternative solar PV systems

Small DIY Solar System requiring City approval

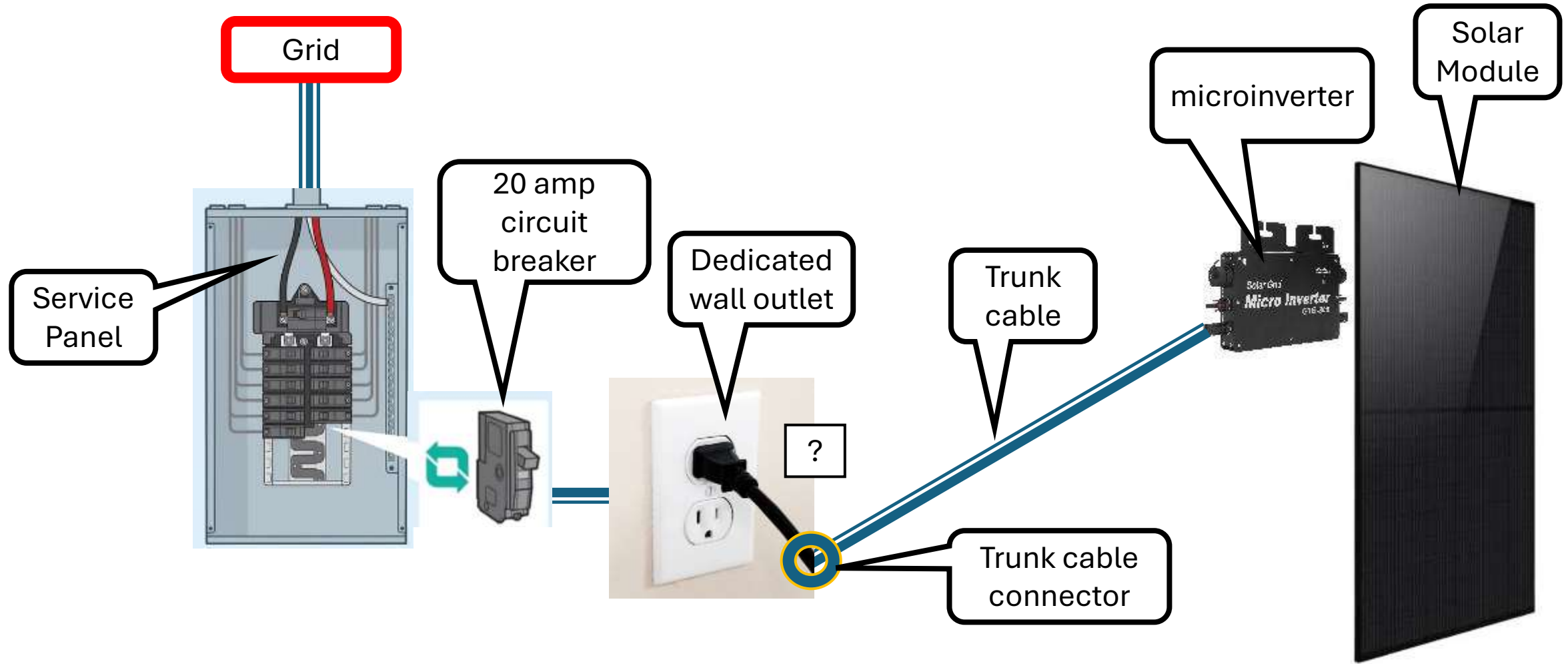

Small DIY Solar System requiring City approval

Annual Value

watts	450
kWh/yr/kWdc	1200
kWh/yr	540
Energy per kWh	\$ 0.09
Transmission per kWh	\$ 0.039
Distribution per kWh	\$ 0.049
Total price per kWh	\$ 0.1777
Total Annual Value	\$96.97

Costs

Longi Solar module	\$ 250
Microinverter	\$ 150
Wiring and wall outlet	\$ 50
Install circuit breaker	\$ 150
Permitting/inspection	\$ 250
Total Costs	\$ 850

First Year ROI

11.4%

Small DIY Off Grid Solar System with charge controller, batteries and DC to AC inverter

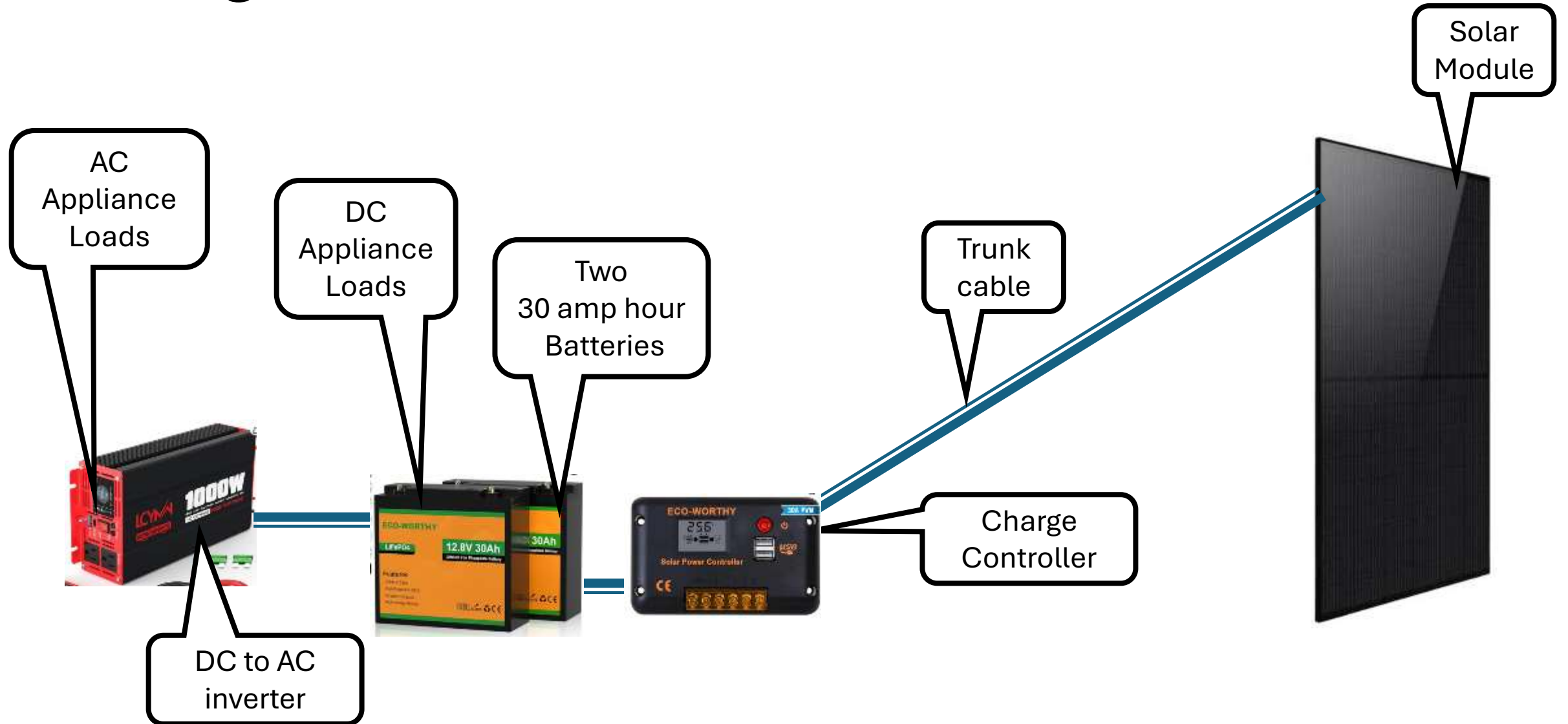

Small DIY Off Grid Solar System with charge controller, batteries and DC to AC inverter

Annual Value

watts	450
kWh/yr/kWdc	1200
kWh/yr	540
Energy per kWh	\$ 0.09
Transmission per kWh	\$ 0.039
Distribution per kWh	\$ 0.049
Total price per kWh	\$ 0.1777
Total Annual Value	\$96.97

Costs

Longi Solar module	\$ 250
Trunk Cable	\$ 50
Charge Controller	\$ 50
Two 30 ah batteries	\$ 250
Pure sine inverter	\$ 130
Total Costs	\$ 730

First Year ROI

13.3%

Small DIY Off Grid Solar System with Power Station

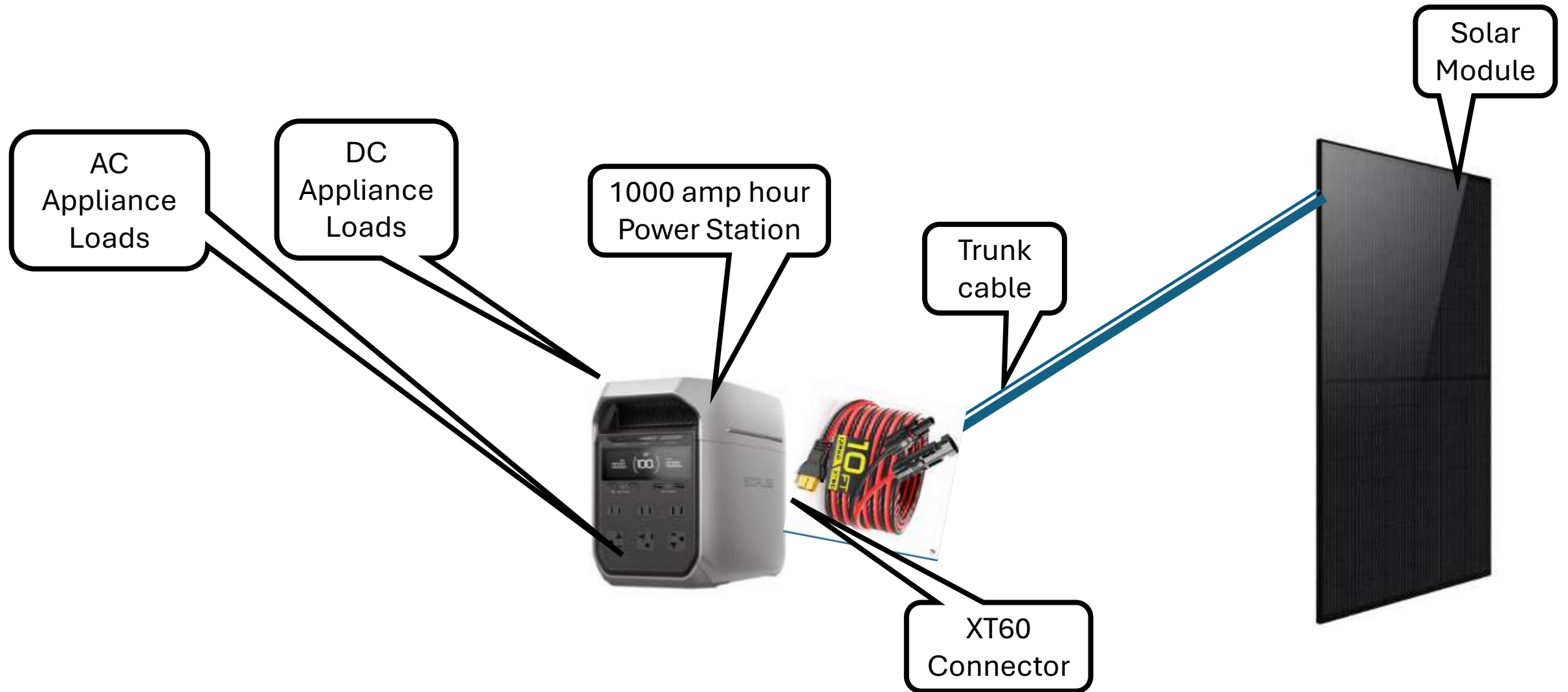

Small DIY Off Grid Solar System with Power Station

Annual Value

watts	450
kWh/yr/kWdc	1200
kWh/yr	540
Energy per kWh	\$ 0.09
Transmission per kWh	\$ 0.039
Distribution per kWh	\$ 0.049
Total price per kWh	\$ 0.1777
Total Annual Value	\$96.97

Costs

Longi Solar module	\$ 250
Trunk Cable	\$ 50
XT60 connector	\$ 20
1000 ah Power Station	\$ 850
Total Costs	\$ 1,170

First Year ROI

8.3%

4.0 kWdc Rooftop Solar System



4.0 kWdc Rooftop Solar System

Annual Value

watts	4,000
kWh/yr/kWdc	1000
kWh/yr	4000
Energy per kWh	\$ 0.09
Transmission per kWh	\$ 0.039
Distribution per kWh	\$ 0.049
Total price per kWh	\$ 0.1777
Total Annual Value	\$ 711

Costs

Current Cost per watt	\$ 2.50
Total Costs	\$ 10,000

First Year ROI

7.1%

Return of Investment Summary

- Rooftop 4.0 kWdc array 7.1%
- Small array with XT60 connector and Power Station 8.3%
- Small array with microinverter and dedicated circuit 11.4%
- Small array with charge controller, batteries and inverter 13.3%

Which Province has the dirtiest grid ?

Provincial Grid intensities for 2023
g CO₂e/kWh

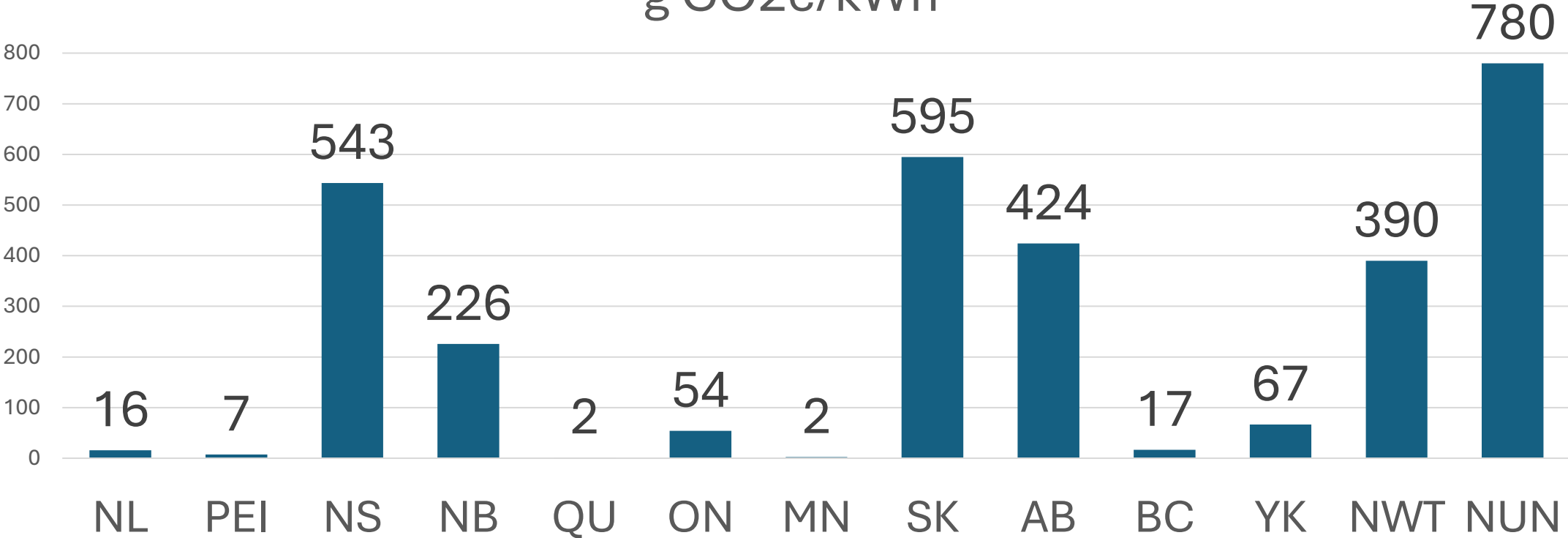

Which Province has the dirtiest grid ?

Provincial Grid Emissions for 2023
kt CO2e

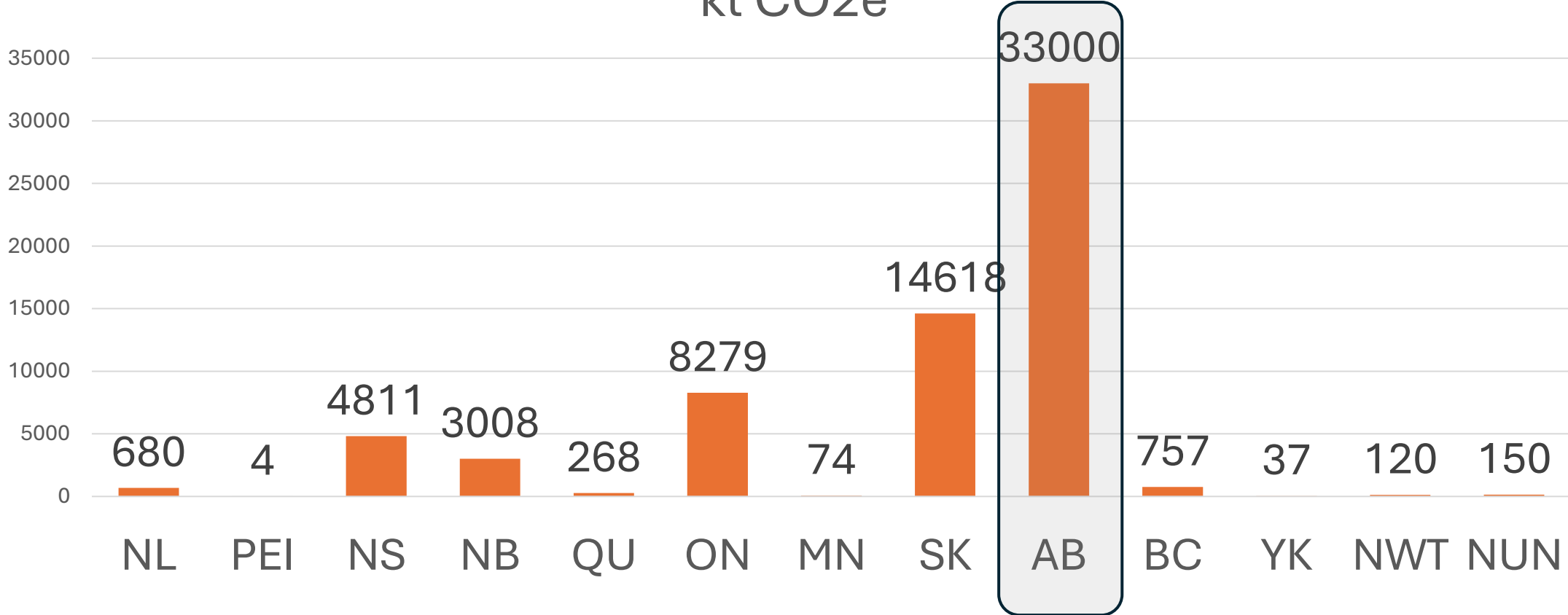

Reducing Carbon emissions generates offsets

- Alberta's grid emission intensity = 424 g CO₂/kWh

Intrinsic value of a \$18,000 solar array

- Assume \$2,500 per kWdc
 - Therefore system size is 7.2 kWdc
 - Assume 1,100 kWh/kWdc yields 7,920 kWh/yr
 - At \$ 0.18 /kWh x 7,920 savings = \$1,426 per year
 - First year Return On Investment = 7.9%
-
- Alberta's grid emission intensity = 424 g CO₂/kWh
 - This array offsets 424g x 7,920 kWh = 3,358,080 g CO₂/yr
 - Equivalent to 3.36 tnes CO₂ / year
 - Current offset value is roughly \$30 per tne CO₂
 - Equates to a **personal** carbon offset value of \$100 per year

Potential in Calgary

- Permitting will be onerous
- PV Array must be 8 feet above ground
- Current systems limited to last year's consumption
 - EV car ?
 - Heat pump?
- Assume typical system offsets 6,000 kWh/yr
- At 1000 kWh/yr/kWdc require 6.0 kW system
- At \$2.50 per watt, **cost will be \$15,000**
- **So why not invest circa \$1,000 and have some fun**